

**INFLUENCE OF NEW AUCTION RULES
AND ELECTRICITY MARKET OPENING
ON SCHEDULING PROCESS
IN 2014 YEAR**

Joint Auctions

Border HR-RS

- HOPS organizes long term auctions and informs EMS about results
- EMS organizes daily auctions and intraday allocations and informs HOPS about results
- Only market participants who has a valid and effective balance responsibility contract with EMS and fulfills the “1:1” – system notification are allowed to use allocated capacity (BRP with defined exclusive cross-border partner on HR-RS border)

- Monthly and yearly allocated capacity for day D will be visible only to BRP with defined exclusive cross-border partner in Scheduling system at 15:15 CET D-2
- Daily capacity for day D is available in Scheduling system at 11:30 CET D-1

MATRIX					HEP OPS	
<Area> 10YCS-SERBIATSOV					10YHR-HEP-----M	
<Capacity Agreement Identification>	<Capacity Contract Type>	Long Term Contract	Yearly	A04	To EMS	From CAO HOPS
					From EMS	From CAO HOPS
			Monthly	A03	To EMS	From CAO HOPS
					From EMS	From CAO HOPS
		DayAhead Contract	Daily	A01	To EMS	RS_HRRS_A01_EIC_DDMMYY
					From EMS	RS_RSHR_A01_EIC_DDMMYY
<MeteringPointIdentification>					To EMS	12ZH1J2ERNMLA11UIN
					From EMS	12ZH1J2ERNMLA11UOUT
EIC is from Rights Holder						

Joint Auctions

Border BG-RS

- ESO organizes long term auctions and informs EMS about results
- EMS organizes daily auctions and informs HOPS about results
- The Allocated Capacity may only be used by the ITR if the ITR fulfills the “1:1” – system notification (registered exclusive cross-border partner on border BG-RS) and has met the following requirements under the Serbian legislation:
 - has valid and effective balance responsibility contract with EMS;
 - is not under bankruptcy or liquidation proceedings;
 - is without any outstanding debts towards EMS

- Yearly and monthly capacities for day D are visible only in Scheduling system till 15:15 CET in day D-3
- Daily capacities for day D are available in Scheduling system at 11:30 CET in D-1

MATRIX					ESO	
<Area> 10YCS-SERBIATSOV					10YCA-BULGARIA-R	
<Capacity Agreement Identification>	<Capacity Contract Type>	Long Term Contract	Yearly	A04	To EMS	From CAO ESO
					From EMS	From CAO ESO
			Monthly	A03	To EMS	From CAO ESO
					From EMS	From CAO ESO
		DayAhead Contract	Daily	A01	To EMS	RS_BGRS_A01_EIC_DDMMYY
					From EMS	RS_RSBG_A01_EIC_DDMMYY
<MeteringPointIdentification>					To EMS	12ZJ2V1NISSOF11EIN
					From EMS	12ZJ2V1NISSOF11EOUT
EIC is from Rights Holder						

Split Auctions

AL-RS, BA-RS, ME-RS, MK-RS

- Scheduling process is without the changes compering to 2013 year

MATRIX				MEPSO				OST				CGES				NOSBiH																							
<Area> 10YCS-SERBIATSOV								10YMK-MEPSO----8								10YAL-KESH-----5								10YCS-CG-TSO---S								10YBA-JPCC-----D							
<Capacity Agreement Identification>	<Capacity Contract Type>	Long Term Contract	Total (Yearly+ Monthly +Weekly)	A05																																			
					To EMS	A05_MKRS_EIC_DDDMMYYYY	A05_ALRS_EIC_DDDMMYYYY	A05_MERS_EIC_DDDMMYYYY	A05_BARS_EIC_DDDMMYYYY																														
		From EMS	A05_RSMK_EIC_DDDMMYYYY	A05_RSAL_EIC_DDDMMYYYY	A05_RSME_EIC_DDDMMYYYY	A05_RSBA_EIC_DDDMMYYYY																																	
		DayAhead Contract	Daily	A01	To EMS	MK_MKRS_A01_EIC_DDDMMYY	AL_ALRS_A01_EIC_DDDMMYY	ME_MERS_A01_EIC_DDDMMYY	BA_BARS_A01_EIC_DDDMMYY																														
					From EMS	MK_RSMK_A01_EIC_DDDMMYY	AL_RSAL_A01_EIC_DDDMMYY	ME_RSME_A01_EIC_DDDMMYY	BA_RSBA_A01_EIC_DDDMMYY																														
<MeteringPointIdentification>					To EMS	12ZY1J2SKOKOS11RIN	12ZJ2A1PRIFIE211IN	12ZJ1J2RIBKOS115IN	12ZJ2WSREUGL11PIN																														
					From EMS	12ZY1J2SKOKOS11ROUT	12ZJ2A1PRIFIE211OUT	12ZJ1J2RIBKOS115OUT	12ZJ2WSREUGL11POUT																														

EIC is from BRP in Serbia 34X.....

Electricity Market Opening

BRP

TRP is responsible for:

- cross-border transactions
- internal transactions

CRP is responsible for balancing of consumer

PRP is responsible for balancing of generation

BRP is obliged to submit as many schedule messages as much roles it has

Schedule Declaration for day D in D-1

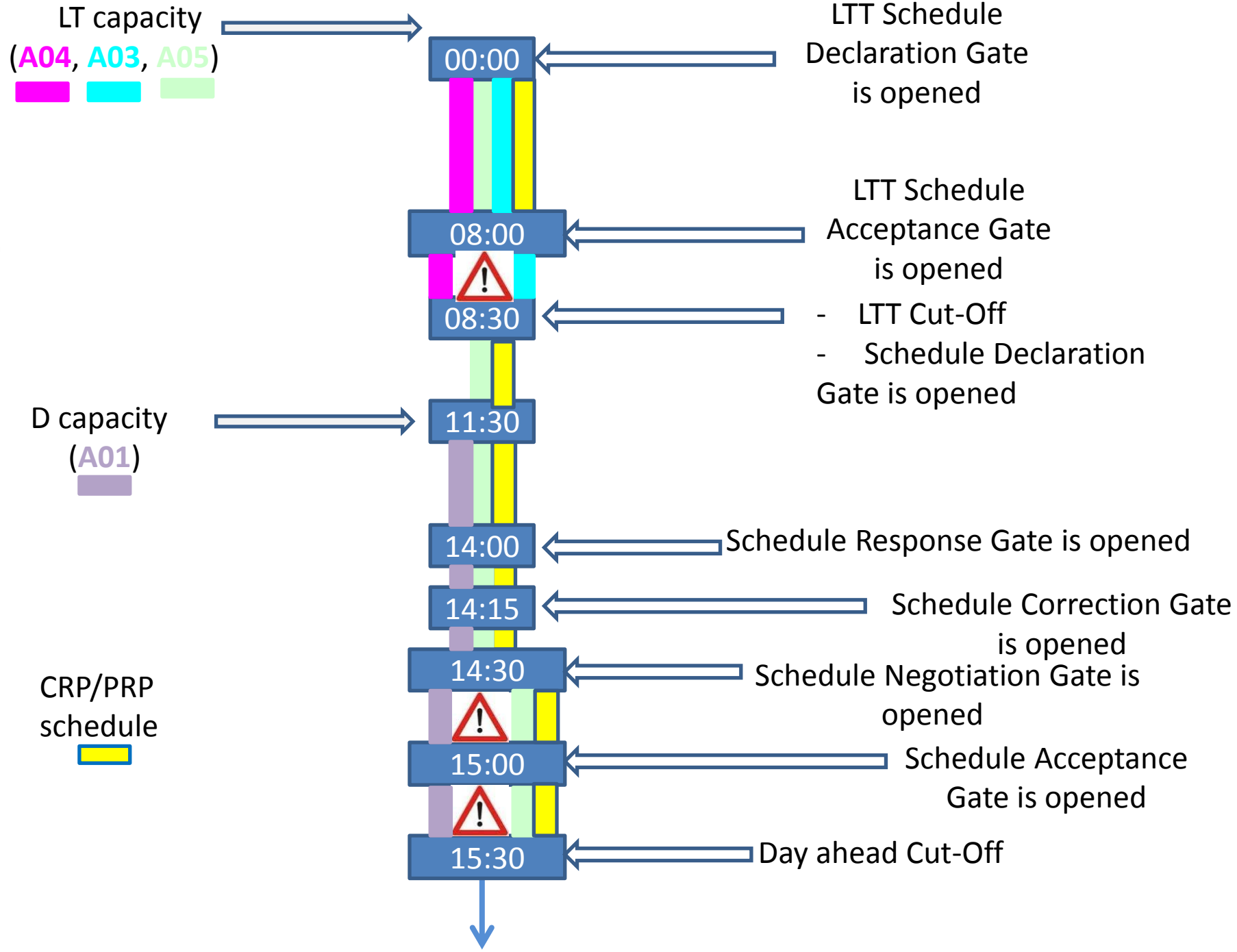

Cross-border Schedule declaration

HR-RS, BG-RS

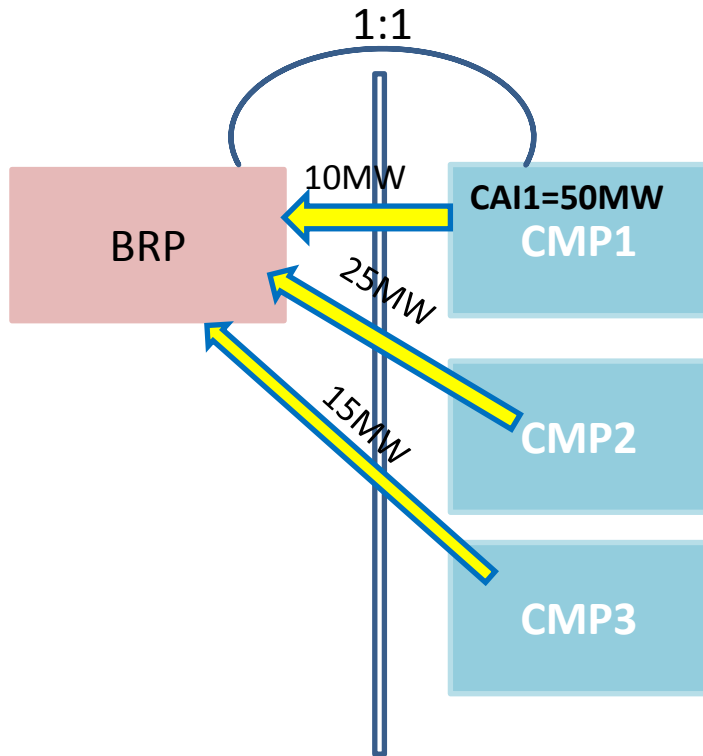

HU-RS, RO-RS

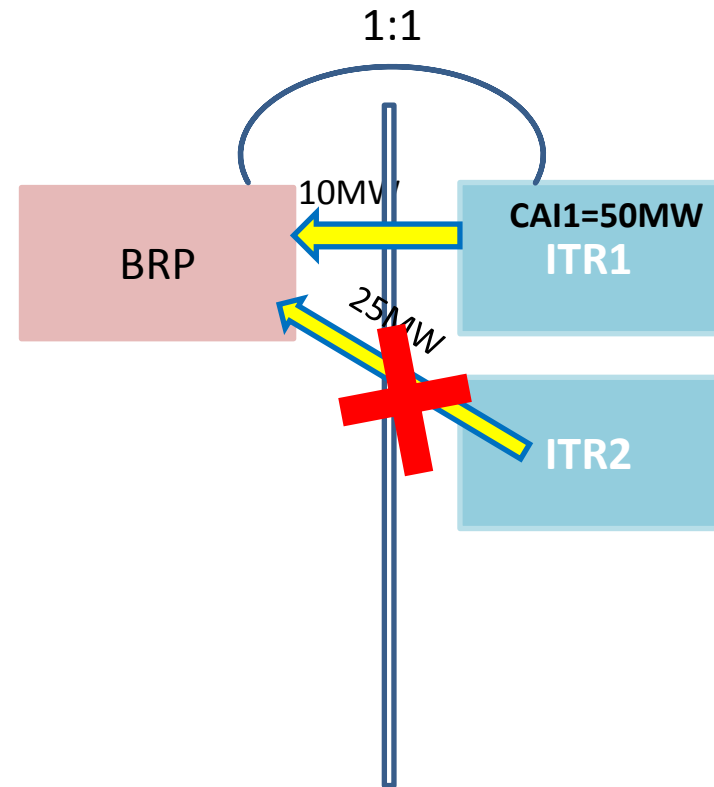

General information

Access to Scheduling system:

- is only allowed to BRP
- Send request to Scheduling and Procurement of Losses Department (schedule@ems.rs) with defined way how do you want to take over Username and password. Recommendation: personally
- Department Manager will answer on your request in 3 days.

“1:1” system notification and Exclusive cross-border partner:

- Registered partner is valid for the whole month
- BRP can have only one exclusive cross-border partner on one border during the month

Deadline for “1:1” system notification 12:00 CET

border BG-RS

Jan	• 12/27/2013
Feb	• 1/29/2014
Mar	• 2/26/2014
Apr	• 3/27/2014
May	• 4/28/2014
Jun	• 5/28/2014
Jul	• 6/26/2014
Aug	• 7/29/2014
Sep	• 8/27/2014
Oct	• 9/26/2014
Nov	• 10/29/2014
Dec	• 11/26/2014

borders HU-RS, RO-RS

Jan	• 12/25/2013
Feb	• 1/27/2014
Mar	• 2/24/2014
Apr	• 3/25/2014
May	• 4/24/2014
Jun	• 5/26/2014
Jul	• 6/24/2014
Aug	• 7/25/2014
Sep	• 8/25/2014
Oct	• 9/24/2014
Nov	• 10/27/2014
Dec	• 11/25/2014

borders HR-RS

24th of previous
month for the next
month

“1:1” – System Notification

This form shall be delivered the following fax numbers:
+381 11 3970 695 and +359 2 981 01 02

The scanned copy of this form shall be delivered to the following e-mail address:
schedule@ems.rs and eso.auction@ndc.bg

	From (<u>dd.mm.yy</u>)	To (<u>dd.mm.yy</u>)
Period (whole calendar month only)		

Form which should
be fulfilled for BG-
RS border

	EMS	ESO
Name of the <i>Interconnection Trade Responsible</i>		
Address		
VAT No.		
EIC-Code		
Company representative		
Telephone No.		
Fax No.		
E-mail address		
Date		
Signature		

“1:1” – System Notification

This form shall be delivered the following fax numbers:
+381 11 3970 695 and +36 1 356 6893

The scanned copy of this form shall be delivered to the following e-mail address:
schedule@ems.rs and arampiac@mavir.hu

	From (dd.mm.yy)	To (dd.mm.yy)
Period (whole calendar month only)		

Form which should
be fulfilled for HU-
RS border

	EMS	MAVIR
Name of the <i>Interconnection Trade Responsible</i>		
Address		
VAT No.		
EIC-Code		
Company representative		
Telephone No.		
Fax No.		
E-mail address		
Date		
Signature		

“1:1” – System Notification

This form shall be delivered the following fax numbers:
+381 11 3970 695 and +4 021 303 56 99

The scanned copy of this form shall be delivered to the following e-mail address:
schedule@ems.rs and tsoplan@transelectrica.ro

	From (<u>dd.mm.yy</u>)	To (<u>dd.mm.yy</u>)
Period (whole calendar month only)		

	EMS	<u>Transelectrica</u>
Name of the <i>Interconnection Trade Responsible</i>		
Address		
VAT No.		
EIC-Code		
Company representative		
Telephone No.		
Fax No.		
E-mail address		

Form which should
be fulfilled for RO-
RS border

Form which should
be fulfilled for HR-RS
border

“1:1” – System Notification

This form shall be delivered the following fax numbers:
+381 11 3970 695

The scanned copy of this form shall be delivered to the following e-mail address:
schedule@ems.rs

	From (dd.mm.yy)	To (dd.mm.yy)
Period (whole calendar month only)		

	EMS	HOPS
Name of Serbian BRP/ Croatian Market participant		
Address		
VAT No.		
EIC-Code		
Company representative		
Telephone No.		
Fax No.		
E-mail address		
Date		
Signature		

Deadline for exclusive cross-border partner 12:00 CET

Form which should be fulfilled for ME-RS, AL-RS, MK-RS, BA-RS borders

24th of previous month for the next month



ЈАВНО ПРЕДУЗЕЋЕ
ЕЛЕКТРОМРЕЖА СРБИЈЕ

ЈП „Електромрежа Србије“
Војводе Степе 412
11000 Београд, Република Србија
Факс: +381 11 3970 217
e-mail: schedule@ems.rs

Рок: 12:00 часова 24. дана у месецу М-1 за месец М за који је регистрација важећа

Именовање ексклузивног прекограничног партнера

Техничка ознака границе	__ - __ - 1)	
Период: (регистрација је важећа за цео календарски месец)	Од: ___.2014. (мм1.2014.)	До: ___.2014. (мм2.2014.) 2)

Оператор преносног система	_____ 3)	ЈП ЕМС
Име Учесника		
Адреса Учесника		
ЕИС код		
Контакт особа		
Број телефона		
Број факса		
Е-mail адреса		
Датум		
Потпис овлашћеног заступника		
Печат		

Потврда ЈП ЕМС

Регистрација: (прихваћена или одбијена)	
Разлог одбијања	
Потпис овлашћеног заступника	

1) МК-RS - за границу регулационих области Македоније и Србије;
 ME-RS - за границу регулационих области Црне Горе и Србије;
 BA-RS - за границу регулационих области БиХ и Србије;
 AL-RS - за границу регулационих области Албаније и Србије;

2) У случају пријаве за више месеци наводи се последњи месец, а у случају пријаве само за један месец - мм2 остаје непопуњено;

3) МЕПСО, ЦГЕС, НОС БиХ или ОСТ.

Curtailement of Allocated Capacity

- The curtailement of Allocated Capacity can be applied before the cut-off time for the matching process.

FINALLY IT'S OVER